

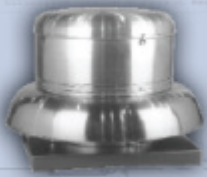

# AIR FLOW, INC

*Range. Support. Experience.*



Warehouse Catalog Edition 2.3

## Table of Contents

---

### Fans and Ventilators

|  |        |
|--|--------|
| Loren Cook Downblast Centrifugal Exhaust Ventilator (Model ACED)     | Page 4 |
| Loren Cook Ceiling Exhaust and Inline Fan (Model GC)                 | Page 5 |
| DeltaBreez Ceiling Exhaust Fans with DC motor technology (Model ITG) | Page 6 |
| Fantech Centrifugal Inline Duct Fans                                 | Page 6 |
| Northwest Envirofan Destratification Fan                             | Page 6 |

### Fan Accessories

|   |        |
|---|--------|
| Cerus X-Drive Stand Alone Variable Frequency Drive                                | Page 7 |
| Cerus X-Drive Variable Frequency Drive with Disconnect                            | Page 7 |
| Franklin Electric Three Phase Combination Building Automation Starter (Model BAS) | Page 8 |
| Franklin Electric Single Phase Building Automation Starter (Model BAS-1P)         | Page 8 |

### Dampers and Actuators

|  |        |
|--|--------|
| Loren Cook Gravity Backdraft Damper                    | Page 4 |
| Ruskin Low Leakage Control Damper (Model CD36)         | Page 9 |
| Ruskin Low Leakage Round Control Damper (Model CDRS25) | Page 9 |
| Belimo Actuators                                       | Page 9 |

### Equipment Support

|                                    |         |
|------------------------------------|---------|
| Equipment Rails 18" High / 18 GA   | Page 10 |
| Equipment Rail Loading Information | Page 10 |
| Roof Curbs 18" High / 18 GA        | Page 11 |
| Pipe Curb Assembly / 18 GA         | Page 11 |

### Gripple Hangers and Supports

|   |            |
|---|------------|
| Gripple: How To Work Out Your Unique Product Code | Page 13    |
| Gripple Fasteners                                 | Page 14-15 |
| Gripple Bulk Cable and Accessories                | Page 15    |
| Gripple Cable and End Fixings                     | Page 16    |

## Table of Contents

---

### Grilles, Registers, and Diffusers

|   |         |
|---|---------|
| Louvered Face Directional Diffuser (Model SMD)                | Page 17 |
| Varitherm Thermally Powered VAV Diffuser (Model VPD-HC)       | Page 17 |
| Square Plaque Diffusers (Model SPD)                           | Page 18 |
| Square Cone Diffuser (Model SCD)                              | Page 18 |
| Round Cone Adjustable Diffuser (Model RCDE)                   | Page 19 |
| Radial Volume Damper (Model VCR9)                             | Page 19 |
| Light Commercial Directional Diffuser (Model LCMD)            | Page 19 |
| Perforated, Lay In, Supply Diffuser (Model PDC)               | Page 20 |
| Perforated, Lay In, Return Diffuser (Model PDDR)              | Page 20 |
| EHG Spiral Mount Grilles with Air Scoops (Model DMR)          | Page 21 |
| Surface Mount Supply Register (Model 520D)                    | Page 23 |
| Fixed Blade Return Grille (Model 530)                         | Page 24 |
| Door Grilles with BF Frame (Model STG1)                       | Page 25 |
| Louvered Face Lay In Filtered Return Grilles (Model 530FF)    | Page 25 |
| Egg Crate Lay In Filtered Return Grilles (Model 80FF - TB)    | Page 25 |
| Egg Crate Grille with Integral Plenum (Model ECRD)            | Page 26 |
| Egg Crate Grille, Lay In and Surface Mount (Model ECR/ECR-TB) | Page 26 |
| Square to Round Transition (Model STR)                        | Page 27 |
| Round to Round Transition (Model RTR)                         | Page 27 |
| Drywall Frame   | Page 27 |

### Slot Diffusers, Fixed

|  |         |
|--|---------|
| Fixed Blade Slot Diffuser (Model J)                            | Page 22 |
| Fixed Blade Slot Plaster Frames (Model J)                      | Page 22 |
| Fixed Blade Slot Diffuser for Flat 9/16" Narrow Grid (Model J) | Page 22 |

### VAV Boxes and Coils

|  |         |
|--|---------|
| Single Duct VAV Terminal Units (Model SDV)       | Page 28 |
| Hot Water Coils for Model SDV VAV Terminal Units | Page 28 |

## Table of Contents

---

### Access Doors

|                      |         |
|----------------------|---------|
| Drywall Access Doors | Page 12 |
| Duct Access Doors    | Page 12 |

---

### Flexible Duct

|   |         |
|---|---------|
| Flexmaster Type 1 Flexible Duct                     | Page 29 |
| Flexmaster Type 6 Acoustic Flexible Duct            | Page 29 |
| FlexRight Elbow for Type 1 and Type 6 Flexible Duct | Page 29 |

---

### Electric Heat

|   |         |
|---|---------|
| Commercial Downflow Ceiling Heaters (Model FFCH)                  | Page 30 |
| Small Room Fan Forced Heaters (Model SRA)                         | Page 31 |
| Architectural Small Wall Heaters (Model SRA1000)                  | Page 31 |
| Commercial Fan Forced Wall Heaters (Model FRC)                    | Page 32 |
| Electric Baseboard Heaters (Model 2500)                           | Page 32 |
| Electric Unit Heaters with Integral Accessories (Model HUHAA PRO) | Page 33 |
| Electric Unit Heaters (Model HUHAA)                               | Page 34 |

---

### Radiant Heat

|                                  |         |
|----------------------------------|---------|
| Hot Water Radiant Ceiling Panels | Page 34 |
|----------------------------------|---------|

---

### GREE Kinghome

|                                     |         |
|-------------------------------------|---------|
| Ultrnixx Heat Pump Condensing Units | Page 35 |
| Ultrnixx Air Handlers               | Page 36 |
| Mini Split Product Overview         | Page 37 |
| Mini Split Performance              | Page 38 |



# Cook

## Model ACED Downblast Centrifugal Exhaust Ventilator—Direct Drive



- All aluminum housing
- Backward inclined all aluminum wheel
- Welded curb cap corners
- Birdscreen
- Factory installed disconnect switch—Prewired
- Factory installed speed switch—Prewired

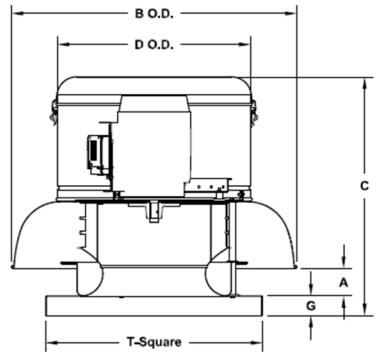

| Model    | CFM Range @ 0.5" SP | HP  | Voltage | B (width) | C (Height) | T (Curb Cap) | Weight | Curb Size | BDD   |
|----------|---------------------|-----|---------|-----------|------------|--------------|--------|-----------|-------|
| 90C15DH  | 100-400             | 1/8 | 115/1   | 18-3/4    | 16.8125    | 18x18        | 28     | 16.5x16.5 | 12x12 |
| 100C15DH | 250-525             | 1/8 | 115/1   | 18-3/4    | 16.8125    | 18x18        | 30     | 16.5x16.5 | 12x12 |
| 101C15D  | 350-700             | 1/8 | 115/1   | 18-3/4    | 16.8125    | 18x18        | 30     | 16.5x16.5 | 12x12 |
| 120C15D  | 600-1350            | 1/4 | 115/1   | 28-7/16   | 26.5625    | 20x20        | 67     | 18.5x18.5 | 14x14 |
| 150C10D  | 1000-1900           | 1/3 | 115/1   | 32-7/8    | 28.6875    | 24x24        | 87     | 22.5x22.5 | 18x18 |

### Gravity Backdraft Damper

Gravity dampers feature an extruded aluminum frame, aluminum blades and aluminum hinge pins with nylon bushings.

Available in sizes:

- 8"x8"
- 10"x10"
- 12"x12"
- 14"x14"
- 16"x16"
- 18"x18"
- 20"x20"
- 22"x22"
- 24"x24"



Wire whips for external signal speed control on Loren Cook EC (Part # 125716) and VF (Part # 125725) fans are also stock items.

# Cook

## Model GC Ceiling Exhaust and Inline Fan

- Forward curved injection molded wheel
- One piece injection molded housing
- Motor isolators
- 6" round outlet with backdraft damper
- Integral disconnect switch
- Factory mounted and wired speed switch



**Gemini 148-188**

| Model  | CFM @ 0.25" SP | Watts | Voltage | Sones |
|--------|----------------|-------|---------|-------|
| GC-148 | 132            | 98    | 115/1   | 2.5   |
| GC-168 | 162            | 145   | 115/1   | 3.5   |
| GC-188 | 244            | 89    | 115/1   | 6.5   |
| GC-422 | 281            | 96    | 115/1   | 4.0   |
| GC-542 | 360            | 122   | 115/1   | 5.5   |
| GC-642 | 548            | 178   | 115/1   | 4.5   |
| GC-740 | 772            | 343   | 11/1    | 6.5   |



**Gemini 242-740**

**Available accessories:**

- Gemini Isolator Kit
- Round duct wall caps with damper in 4", 6", 8" sizes
- Rectangular wall caps in sizes 8.3"x6.375" and 10.8"x5"
- Inline adaptor kits for models GC-128 - 188.  
Not needed for models GC-242 -740.



# DeltaBreez

## Ceiling Exhaust Fans with DC motor technology



DeltaBreez ITG100

| Model  | CFM @ 0.10" SP | Watts | Voltage | Sones | Outlet |
|--------|----------------|-------|---------|-------|--------|
| ITG80  | 80             | 10    | 115/1   | 1.3   | 4"     |
| ITG100 | 100            | 17.0  | 115/1   | 1.5   | 4"     |

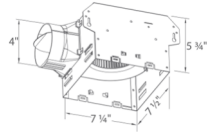

DeltaBreez ITG80

- ENERGY STAR qualified with DC motor technology
- Quiet operation
- Compact housing for easy retrofit and replacement of older bath fans
- UL listed for both ceiling mount and wall mount installation

# Fantech

## Centrifugal Inline Duct Fans with Metal Housings

| Model  | CFM @ 0.20" SP | Watts | Voltage | Duct Dia. |
|--------|----------------|-------|---------|-----------|
| FG4XL  | 150            | 78    | 120/1   | 4"        |
| FG6XL  | 300            | 67    | 120/1   | 6"        |
| FG8XL  | 450            | 137   | 120/1   | 8"        |
| FG10XL | 560            | 190   | 120/1   | 10"       |



- Multipurpose inline duct fan for exhaust or supply air
- 4", 6", 8", and 10" round back draft dampers available
- Optional WC15 speed control

# Northwest Envirofan

## Destratification Fans



- Available in 48" and 56" blade sizes
- Fan Speed Switches (for 2, 5 or 8 fans)
- 30" Extended Down Rods



# Franklin Electric

## Cerus X-Drive Stand Alone VFD

- Programmable Input/Output terminal options
- Smartphone operation via Bluetooth®
- Compatible with three-phase induction or permanent magnet motors
- **CXD App Features:** Damper control, dual demand controls, automated scheduling, multi-motor and multi-drive, pump specific features (sleep mode, screen clean, etc.)
- Designated HOA functionality
- NEMA & UL Type 1 enclosure
- Communications for multi-drive operations—up to eight VFDs



| Model Number | Voltage     | HP   |
|--------------|-------------|------|
| CXD-015A-2V  | 208V / 230V | 1-3  |
| CXD-031A-2V  | 208V / 230V | 5-10 |
| CXD-005A-4V  | 460V        | 1-3  |
| CXD-018A-4V  | 460V        | 5-10 |

## Cerus X-Drive VFD with Disconnect

- VFD with UL Type 1 enclosed MMS disconnect
- 5% line reactor
- FE Connect
- Easy time saving installation with slim-line design

| Model Number       | Voltage     | HP    |
|--------------------|-------------|-------|
| XD1-DISC0078-2V-8  | 208V / 230V | 1-2   |
| XD1-DISC0152-2V-17 | 208V / 230V | 3-5   |
| XD1-DISC0253-2V-26 | 208V / 230V | 5-7.5 |
| XD1-DISC0034-4V-4  | 460V        | 1-2   |
| XD1-DISC0076-4V-8  | 460V        | 3-5   |
| XD1-DISC0140-4V-17 | 460V        | 5-10  |



# Franklin Electric

## Model BAS Smartstart Starters

### Combination Versions Include Disconnect

### Specifications

- Motor circuit protection disconnect provides branch and short circuit protection
- High interrupting ratings for maximum electrical system compatibility
- No fuses required—save time and money
- Lockable handle for safety

- Starter Type: Building Automation Starter
- Standard or Combination
- UL Type 1 or UL Type 4/12 Enclosure
- User Interface
- Hands-Off-Auto keypad with LEDs
- Watertight membrane

- LED pilot lights
- Hand, Off, Auto, Run Overload



### Three Phase Combination Building Automation Starters

| Model #          | 208V       | 230V       | 460V         |
|------------------|------------|------------|--------------|
| BAS1-9/P-G1.6-40 | -          | -          | 1/2 - 3/4 HP |
| BAS1-9/P-G2.5-40 | 1/2 HP     | 1/2 HP     | 1 HP         |
| BAS1-9/P-G4-40   | 3/4 HP     | 3/4 HP     | 1.5 - 2 HP   |
| BAS1-9/P-G6-40   | 1 HP       | 1 - 1.5 HP | 3 HP         |
| BAS1-9/P-G8-40   | 1.5 - 2 HP | 2 HP       | 5 HP         |
| BAS1-18/P-G10-40 | 2 HP       | 3 HP       | 5 HP         |
| BAS1-18/P-G13-40 | 3 HP       | 3 HP       | 7.5 HP       |
| BAS1-18/P-G17-40 | -          | 5 HP       | 10 HP        |
| BAS1-32/P-G22-40 | 5 HP       | 7.5 HP     | 15 HP        |
| BAS1-32/P-G26-40 | 7.5 HP     | 7.5 HP     | 15 HP        |
| BAS1-32/P-G32-40 | 10 HP      | 10 HP      | 20 HP        |

### Model BAS-1P Starters

### Single Phase Combination Building Automation Starters

- On/Off Disconnect Switch with Recessed Hand/Auto Modes
- Run Status Verification
- Voltage & Dry Inputs for Auto Run Command
- Wide Range Class 10 Electronic Overload

| Model # | 120V        | 230V        |
|---------|-------------|-------------|
| BAS-1P  | 1/10 - 1 HP | 1/10 - 1 HP |



# Ruskin

## Model CD36 Low Leakage Control Damper—Opposed Blade

- 6" x 1/2" control shaft
- 16 gauge frame
- 16 gauge 6" blades
- Blade and jamb seals



Available in sizes:

- 10"x10"
- 12"x12"
- 14"x14"
- 16"x16"
- 18"x18"
- 20"x20"
- 24"x12"
- 24"x24"
- 30"x30"
- 36"x24"
- 36"x36"
- 42"x42"
- 48"x24"
- 48"x48"

## Model CDRS25 Low Leakage Round Control Damper

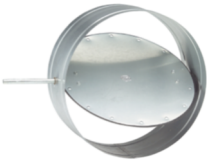

Available in sizes:

- 6"
- 8"
- 10"
- 12"
- 14"
- 16"

## Model HQR050B Hand Quadrant

- Galvanized steel hand quadrant for 1/2" round shaft.
- Compatible with 2" standoff.

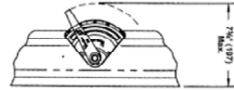

# Belimo

## Damper Actuators

Internal & external linkage kits available



| Model     | Voltage | Aux. Switch Available | Torque    | Recommended Damper Size |
|-----------|---------|-----------------------|-----------|-------------------------|
| TFB24(S)  | 24V     | Yes                   | 18 in-lb  | 4.5 sqft                |
| LF24(S)   | 24V     | Yes                   | 35 in-lb  | 8.0 sqft                |
| NFB24(S)  | 24V     | Yes                   | 90 in-lb  | 22 sqft                 |
| TFB120(S) | 120V    | Yes                   | 18 in-lb  | 4.5 sqft                |
| LF120(S)  | 120V    | Yes                   | 35 in-lb  | 8.0 sqft                |
| NFBUP(S)  | 24-240V | Yes                   | 90 in-lb  | 22 sqft                 |
| AFBUP(S)  | 24-240V | Yes                   | 180 in-lb | 45 sqft                 |

# The Pate Company

## Equipment Rails 18" High / 18 Gauge

| Model | Length | Width | Nailer |
|-------|--------|-------|--------|
| ES-2  | 2'-0"  | 6"    | 2"x6"  |
| ES-2  | 3'-0"  | 6"    | 2"x6"  |
| ES-2  | 4'-0"  | 6"    | 2"x6"  |
| ES-2  | 5'-0"  | 6"    | 2"x6"  |
| ES-2  | 6'-0"  | 6"    | 2"x6"  |
| ES-2  | 8'-0"  | 6"    | 2"x6"  |

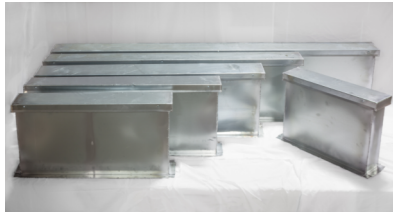

## Equipment Rail Loading Information

|  |          |
|--|----------|
| Style  | ES-2     |
| Width & Height                               | 5-1/2x18 |
| Area IN                                      | 1.775    |
| Moment of Inertia IN                         | 37.800   |
| Section Modulus IN                           | 4.85     |
| Maximum Allowable Concentrated Load Lbs.     | 4300     |
| Maximum Allowable End Reaction Lbs.          | 4100     |
| Maximum Allowable Intermediate Reaction Lbs. | 4100     |
| Maximum Allowable Uniform Load Lb./Ft.       | 1300     |

# The Pate Company

## Roof Curbs 18" High / 18 Gauge

| Model | O.D.        | I.D.        | Cook Fan Sizes          |
|-------|-------------|-------------|-------------------------|
| PC-2  | 16.5"x16.5" | 13.5"x13.5" | 60, 70, 80, 90, 100     |
| PC-2  | 18.5"x18.5" | 15.5"x15.5" | 120, 135                |
| PC-2  | 22.5"x22.5" | 19.5"x19.5" | 150, 165                |
| PC-2  | 28.5"x28.5" | 25.5"x25.5" | 180, 195, 210, 225, 245 |
| PC-2  | 34.5"x34.5" | 31.5"x31.5" | 270, 300                |
| PC-2  | 40.5"x40.5" | 37.5"x37.5" | 330, 365                |
| PC-2  | 46.5"x46.5" | 43.5"x43.5" | 402                     |

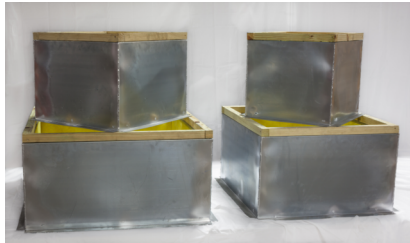

## Pipe Curb Assembly / 18 Gauge

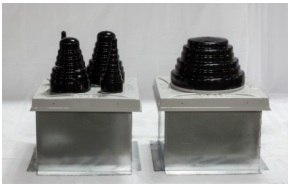

| Curb Model | Curb Size O.D. |
|------------|----------------|
| PCA-2      | 15"x15"        |

| Cap Model | Pipe Sizes                      |
|-----------|---------------------------------|
| PCC-1     | (4) 1/2"-2 7/8"                 |
| PCC-3     | (2) 1/2"-2 7/8" & (2) 3"-5 1/2" |
| PCC-4     | (1) 6"-10 3/4"                  |
| PCC-5     | (5) 1/2"-2 7/8"                 |

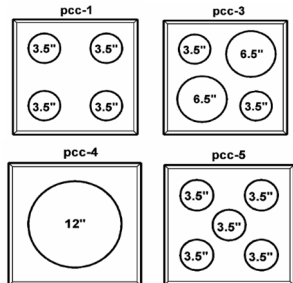



## Acudor

## Model UF-5000 Drywall Access Doors



- Universal flush access door for walls and ceilings; designed for installation in drywall, plaster, masonry, tile or any flush surface
- The door panel features rounded safety corners, which provide an architecturally pleasing appearance
- The one-piece trim flange will not rack, sag or distort
- The unique continuous concealed hinge will not bind or corrode, allowing the door to operate freely time and time again
- For easy installation, the mounting frame is 1 1/4" deep, giving maximum clearance behind the door frame

Available in sizes:

- 12"x12"
- 18"x18"
- 24"x24"

## Model CD-5080 Duct Access Doors

- Removable, Insulated door panel, along with gasketing between the door and frame
- 5/8" notched knock over tabs on the inside of the frame provide for easy installation
- These doors are designed for use in low to medium pressure up to 3" static W.G.

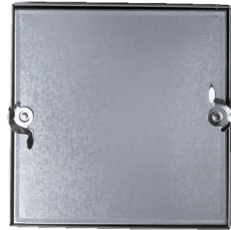

Available in sizes:

- 6"x6"
- 8"x8"
- 12"x12"
- 14"x14"
- 16"x16"
- 18"x18"
- 24"x24"

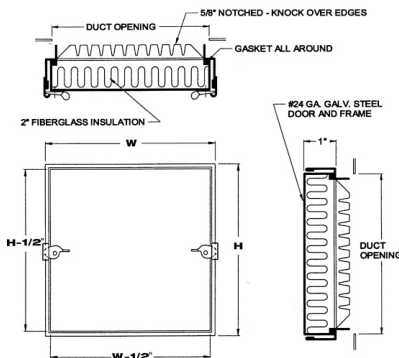





# Gripple

## How to work out your unique Gripple product



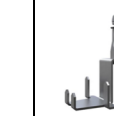

Gripple's range of time and labor saving supports and hangers were developed to provide a versatile solution for suspending a variety of equipment.

### 1) Choose your fastener

The Safe Working Load varies by fastener. Based on your working load, the applicable fastener and cable should be selected.

|   |   |   |   |   |   |
|---|---|---|---|---|---|
|  |  |  |  |  |  |
| Butterfly Trapeze   | Duct Trapeze  | Standard Hanger   | Express Hanger  | UniGrip   | UniGrip - Phenolic Adaptor  |

### 2) Choose your end fixing

|  |  |  |  |  |
|--|--|--|--|--|
|  |  |  |  |  |
| Loop   | Shot Fire  | 90° Eyelet   | Stud   | Swivel Toggle  |

### 3) Choose your cable length









|     |      |      |      |            |
|-----|------|------|------|------------|
| 5FT | 10FT | 15FT | 20FT | 500FT REEL |
|-----|------|------|------|------------|

**FASTENER + END FIXING + CABLE LENGTH**

# Gripple

## Fasteners



Gripple's patented suspension systems for the installation of HVAC, mechanical, lighting, electrical, and signage services. A faster, safer, more cost effective and energy efficient alternative to threaded rod and strut.

| Product  | Model / Safe Working Load  | Description   | Features  | Quantity                  |
|--|----------------------------|---|---|---------------------------|
|    | BT2 10BB<br>100 lbs        | Butterfly trapeze hanger for No. 2 Gripple cable                          | One-way fastener for the fast suspension of rectangular duct and similar equipment in an indoor stationary setting  | Pack of 10 Fasteners only |
|    | DT2 ACC<br>100 lbs         | Duct trapeze hanger for No. 2 Gripple cable                               | One-way fastener for the fast suspension of rectangular duct and similar equipment in an indoor stationary setting  | Pack of 10 Fasteners only |
|    | HF2 10BB<br>100 lbs        | Standard hanger for No. 2 Gripple cable                                   | Fastener for the fast suspension of a variety of services in an indoor stationary setting   | Pack of 10 Fasteners only |
|    | HF3 10BB<br>200 lbs        | Standard hanger for No. 3 Gripple cable                                   | Fastener for the fast suspension of a variety of services in an indoor stationary setting   | Pack of 10 Fasteners only |
|   | UG2 10BB<br>120 lbs        | UniGrip fastener for No. 2 Gripple cable                                  | Fastener designed for fast suspension of cable containment, piping, ductwork, HVAC systems and modules  | Pack of 10 Fasteners only |
|  | UG3 10BB<br>240 lbs        | UniGrip fastener for No. 3 Gripple cable                                  | Fastener designed for fast suspension of cable containment, piping, ductwork, HVAC systems and modules  | Pack of 10 Fasteners only |
|  | UG2 PA 10BB                | UniGrip fastener w/ phenolic adapter                                      | An efficient phenolic ductwork suspension solution, which utilizes four precisely positioned teeth to attach directly to the ductwork                                     | Pack of 10 Fasteners only |
|  | UG2-3/8-FN-10BB<br>120 lbs | UniGrip fastener w/ 3/8" stud, cable center exit, for use with No.2 cable | UniGrip™- Central Exit is designed for services suspended with channel. Supplied with flange hex nut, featuring a thread size of 3/8" (UniGrip #2) for mechanical fixing. | Pack of 10 Fasteners only |
|  | UG3-3/8-FN-10BB<br>240 lbs | UniGrip fastener w/ 3/8" stud, cable center exit, for use with No.3 cable | UniGrip™- Central Exit is designed for services suspended with channel. Supplied with flange hex nut, featuring a thread size of 3/8" (UniGrip #3) for mechanical fixing. | Pack of 10 Fasteners only |







# Gripple

## Fasteners

Gripple's range of HVAC hangers supplied as a ready-to-use kit comprising a length of cable with pre-attached end fixing ensure significant savings in time and labor costs when suspending all types of heating, ventilation, and air conditioning systems.

| Product  | Model / Safe Working Load  | Description   | Features  | Quantity                  |
|--|----------------------------|---|---|---------------------------|
|  | UG4-1/2-FN-10BB<br>550 lbs | UniGrip fastener w/ 1/2" stud, cable center exit, for use with No.4 cable | UniGrip™- Central Exit is designed for services suspended with channel. Supplied with flange hex nut, featuring a thread size of 1/2" (UniGrip #4) for mechanical fixing. | Pack of 10 Fasteners only |
|  | XP2 10BB<br>100 lbs        | Express fastener w/ button adjustment, for use w/ No.2 cable              | Cable hanger for the fast suspension of a variety of services in an indoor stationary setting. Featuring a push-button release fastener for easier height adjustments.    | Pack of 10 Fasteners only |















## Bulk Cable and Accessories

| Product  | Model / Safe Working Load | Description                 | Features   | Quantity  |
|--|---------------------------|-----------------------------|--|-----------|
|  | 2MM 500FT REEL            | Galvanized Bulk Wire Rope   | 500 feet of No. 2 cable (5/64") with 7x7 strand configuration  | 1 Reel    |
|  | 3MM 500FT REEL            | Galvanized Bulk Wire Rope   | 500 feet of No. 3 cable (1/8") with 7x7 strand configuration   | 1 Reel    |
|  | GRP CUTTERS               | Small Cable Cutter          | Designed for cutting cable sizes No. 1 - 4. Hardened jaws for durability   | 1 Tool    |
|  | GRP KEY FLAG              | Blue Key Flag               | For use with Gripple hanger sizes No.1-3   | 1 Flag    |
|  | SX ADP 3/8                | Spider Threaded Rod Adapter | 3/8" Threaded Rod Adapter  | 1 Adapter |
|  | TPZ BRACKET               | Trapeze Bracket             | For use with No. 2 or No. 3 UniGrip Hanger on rectangular ducting to replace the need for threaded rod or duct strap | 1 Bracket |

# Gripple

## Cable and End Fixings

Gripple's range of suspension systems provide a fast, versatile, and aesthetic solution for securing all types of equipment.

| Product   | Model / Safe Working Load  | Description  | Quantity        |
|---|----------------------------|--|-----------------|
|     | UG3 EY90QG 10FT<br>240 lbs | UniGrip for No. 3 Gripple cable with 1/4" 90 Degree Eyelet End Fixing and 10 feet of cable   | Pack of 10 kits |
|    | SL2 5FT                    | No. 2 Loop end fixing with 5 feet of cable   | Pack of 10      |
|    | SL2 10FT                   | No. 2 Loop end fixing with 10 feet of cable  | Pack of 10      |
|    | SL2 15FT                   | No. 2 Loop end fixing with 15 feet of cable  | Pack of 10      |
|    | SL2 20FT                   | No. 2 Loop end fixing with 20 feet of cable  | Pack of 10      |
|    | SL3 10FT                   | No. 3 Loop end fixing with 10 feet of cable  | Pack of 10      |
|    | SL3 20FT                   | No. 3 Loop end fixing with 20 feet of cable  | Pack of 10      |
|   | SL02-3M/10FT-SF35          | No. 2 1.25" Pin & Ceiling Clip Shot Fire end fixing with 10 feet of cable. A hanger solution with pre-mounted nail end fixing, for securing installation into concrete or composite metal decking. | Pack of 10      |
|  | SS3/8-02-3M/10FT           | No. 2 3/8" Stud end fixing with 10 feet of cable   | Pack of 10      |
|  | SS3/8-03-3M/10FT           | No. 3 3/8" Stud end fixing with 10 feet of cable   | Pack of 10      |
|  | SS3/8-03-6M/20FT           | No. 3 3/8" Stud end fixing with 20 feet of cable   | Pack of 10      |
|  | SS3/8-04-3M/10FT           | No. 4 3/8" Stud end fixing with 10 feet of cable   | Pack of 10      |
|  | SSEYE90QG-02-3M/10FT       | No. 2 1/4" 90 Degree Eyelet end fixing with 10 feet of cable   | Pack of 10      |
|  | SSXT2G-02-3M/10FT          | No. 2 Swivel Toggle end fixing with 10 feet of cable   | Pack of 10      |

# Price

## Model SMD Louvered Face Directional Diffuser

| Neck Size | Panel Size | CFM Range | Border |
|-----------|------------|-----------|--------|
| 6"x6"     | -          | 0-200     | 6      |
| 9"x9"     | -          | 210-450   | 6      |
| 12"x12"   | -          | 400-775   | 6      |
| 15"x15"   | -          | 625-1050  | 6      |
| 6"x6"     | 24"x24"    | 0-200     | 3P     |
| 9"x9"     | 24"x24"    | 210-450   | 3P     |
| 12"x12"   | 24"x24"    | 400-775   | 3P     |
| 15"x15"*  | 24"x24"    | 625-1050  | 3P     |

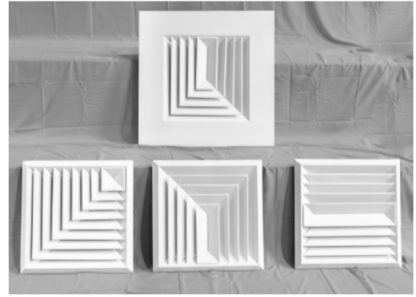

- Steel Construction
- White Powder Coat Finish
- Spring Loaded Removable Core
- Core Styles for 2-, 3-, 4-Way throw
- Border 3P—Lay In Ceiling
- Border 6—Beveled Frame Surface Mount
- Square to Round Adaptors and Surface Mount Frames Available

\*Available in 4-way aluminum construction

**Border: 3P Steel T-Bar Panel Lay-In 1" (25)**

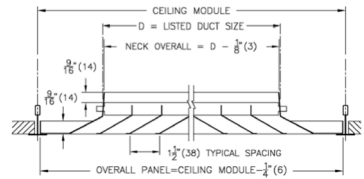

**Border: 6 Beveled Frame Surface Mount**

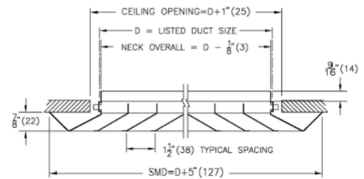

## Model VPD-HC Varitherm Thermally Powered VAV Diffuser



- VAV Heating and Cooling
- Auto Heat / Cool Changeover
- Minimum Airflow Adjustment / Balancing Mode From The Face
- Hinged Plaque with Magnetic Closure
- Steel Backpan and Plaque
- White Powder Coat Finish
- Available in 12" neck size
- 24"x24" Panel Size

# Price

## Model (A)SPD Square Plaque Diffuser

| Neck Size | Panel Size | CFM Range | Available Models |
|-----------|------------|-----------|------------------|
| 6"        | 12"x12"    | 0-150     | SPD              |
| 8"        | 12"x12"    | 140-280   | SPD              |
| 6"        | 24"x24"    | 0-150     | SPD / ASPD       |
| 8"        | 24"x24"    | 140-280   | SPD / ASPD       |
| 10"       | 24"x24"    | 215-435   | SPD / ASPD       |
| 12"       | 24"x24"    | 315-625   | SPD / ASPD       |
| 14"       | 24"x24"    | 430-855   | SPD              |



- Steel (SPD) or Aluminum (ASPD) Construction
- White Powder Coat Finish
- Available standard inlet neck; some sizes available with beaded necks
- Surface Mount Frames, Dampers, and Air Baffles Available

## Model (A)SCD Square Cone Diffuser



| Neck Size | Panel Size | CFM Range | Available Models |
|-----------|------------|-----------|------------------|
| 6"        | 12"x12"    | 0-150     | SCD              |
| 8"        | 12"x12"    | 140-280   | SCD              |
| 6"        | 24"x24"    | 0-150     | SCD / ASCD       |
| 8"        | 24"x24"    | 140-280   | SCD / ASCD       |
| 10"       | 24"x24"    | 215-435   | SCD / ASCD       |
| 12"       | 24"x24"    | 315-625   | SCD / ASCD       |
| 14"       | 24"x24"    | 430-855   | SCD              |

Some sizes available with Beaded Inlet Neck (2.5" extended depth) and Removable Core—Without Tools

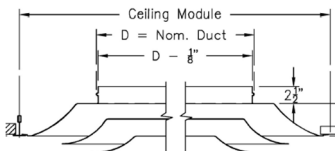

All sizes available with Standard inlet neck and Fixed Core.

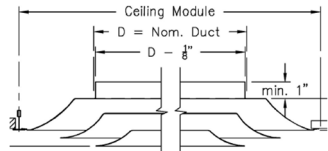

- Steel (SCD) or Aluminum (ASCD) Construction
- White Powder Coat Finish
- 360 Degree Fixed Air Pattern
- Surface Mount Frames, Dampers, and Sectorizing Baffles Available

# Price

## Model RCDE Round Cone Adjustable Diffuser



| Inlet Size | Outside Diameter | CFM Range |
|------------|------------------|-----------|
| 6"         | 11-1/8"          | 80-160    |
| 8"         | 14-3/4"          | 140-280   |
| 10"        | 18-1/4"          | 220-435   |
| 12"        | 22"              | 315-630   |

- Steel Construction
- White Powder Coat Finish
- Radial Dampers Available
- 360 Degree Adjustable Air Pattern

## Model VCR9 Radial Volume Damper

Available in sizes:

- 6"
- 8"
- 10"
- 12"
- 14"

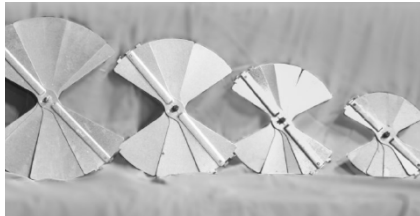

## Model LCMD Light Commercial Directional Diffuser



- Extruded Aluminum Diffuser Construction with Steel Opposed Blade Damper with Lever Operator
- White Powder Coat Finish
- All are 4-Way Throw
- Surface mount beveled frame with screwholes

| Neck Size | Panel Size | CFM Range |
|-----------|------------|-----------|
| 6"x6"     | -          | 0-200     |
| 8"x8"     | -          | 210-450   |
| 10"x10"   | -          | 400-775   |
| 12"x12"   | -          | 625-1050  |

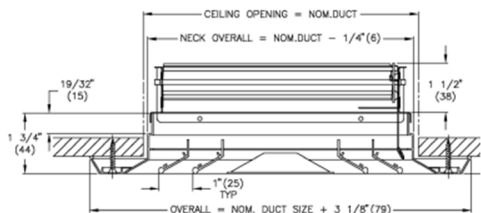



# Price

## Model PDC Perforated Supply Diffuser with Neck Mounted Adjustable Curved Blades—Lay In



| Neck Size | Panel Size | CFM Range |
|-----------|------------|-----------|
| 6"        | 24"x24"    | 0-150     |
| 8"        | 24"x24"    | 140-280   |
| 10"       | 24"x24"    | 215-435   |
| 12"       | 24"x24"    | 315-625   |

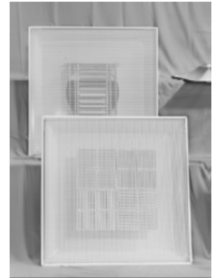

- Steel Construction
- White Powder Coat Finish
- Hinged Removable Face
- Adjustable Deflectors
- Surface Mount Frames and Dampers Available

## Model PDDR Perforated Return / Transfer / Exhaust Grilles

| Neck Size | Panel Size | CFM Range |
|-----------|------------|-----------|
| 6"        | 24"x24"    | 0-125     |
| 8"        | 24"x24"    | 70-210    |
| 10"       | 24"x24"    | 110-330   |
| 12"       | 24"x24"    | 155-475   |
| 14"       | 24"x24"    | 205-625   |
| 16"       | 24"x24"    | 245-800   |
| 22"x22"   | 24"x24"    | 670-2000  |
| 22"x10"   | 24"x12"    | 300-900   |

- Steel Construction
- White Powder Coat Finish
- Hinged Removable Face
- Surface Mount Frames and Dampers Available

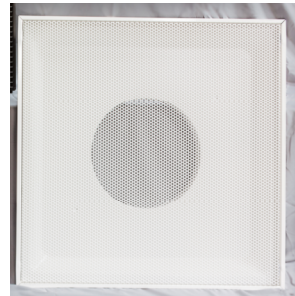

# EHG

## Model DMR Spiral Mount Grilles with Air Scoops

| Size                     | CFM (*) | Throw<br>(150-100-50 fpm) | NC | Minimum Duct<br>Diameter |
|--------------------------|---------|---------------------------|----|--------------------------|
| 13"x3"                   | 144     | 14 - 17 - 32              | 25 | 6"                       |
| 17"x3"                   | 192     | 14 - 18 - 34              | 29 | 6"                       |
| 21"x3"                   | 240     | 14 - 19 - 36              | 31 | 6"                       |
| 13"x6"                   | 288     | 14 - 20 - 38              | 31 | 12"                      |
| 17"x6"                   | 384     | 15 - 22 - 41              | 37 | 12"                      |
| 21"x6"                   | 480     | 15 - 23 - 44              | 40 | 12"                      |
| 25"x6"                   | 584     | 15 - 23 - 44              | 40 | 12"                      |
| 21"x9"                   | 800     | 16 - 26 - 49              | 46 | 20"                      |
| 25"x9"                   | 960     | 17 - 26 - 49              | 48 | 20"                      |
| (*) CFM based on 800 FPM |         |                           |    |                          |

- Steel construction with adjustable blades
- Double deflection—3/4" spacing
- Mill finish

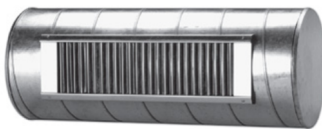

# Raymon-Donco

## Model J Fixed Blade Slot Diffuser

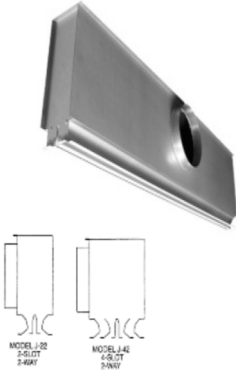

| Model | Length | Slots  | Inlet | Available with Center Notch | CFM Range |
|-------|--------|--------|-------|-----------------------------|-----------|
| J22   | 24"    | 2-slot | 6"    | -                           | 80-160    |
| J22   | 24"    | 2-slot | 8"    | -                           | 80-160    |
| J22   | 48"    | 2-slot | 6"    | Yes                         | 125-175   |
| J22   | 48"    | 2-slot | 8"    | Yes                         | 175-250   |
| J22   | 48"    | 2-slot | 10"   | Yes                         | 250-325   |
| J42   | 48"    | 4-slot | 10"   | Yes                         | 325-500   |
| J42   | 48"    | 4-slot | 12"   | Yes                         | 325-500   |

- Oval inlets and low profile plenums
- White face
- Integral side-T's

## Model J Fixed Blade Slot Plaster Frames

| Model | Length | Slots  | Ceiling Opening |
|-------|--------|--------|-----------------|
| JF22  | 24"    | 2-slot | 24.75"x4.75"    |
| JF22  | 48"    | 2-slot | 48.75"x4.75"    |
| JF42  | 48"    | 4-slot | 48.75"x7.25"    |

- White finish
- Mounting clips



## Model J Fixed Blade Slot Diffuser for Flat 9/16" Narrow Grid

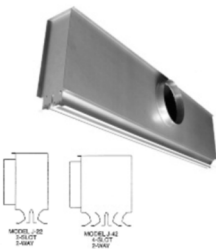

| Model | Length | Slots  | Inlet | CFM Range |
|-------|--------|--------|-------|-----------|
| J22   | 24"    | 2-slot | 6"    | 80-160    |
| J22   | 48"    | 2-slot | 8"    | 175-250   |
| J22   | 48"    | 2-slot | 10"   | 250-325   |

- Oval inlets and low profile plenums
- Integral side-T's
- White face
- Center notch available on 48" long slot diffusers

# Price

## Model 520D—Surface Mount Supply Register

Width

|        | 6"  | 8" | 10" | 12" | 14" | 16" | 18" | 20" | 22" | 24" | 30" | 36" |   |
|--------|-----|----|-----|-----|-----|-----|-----|-----|-----|-----|-----|-----|---|
| Height | 4"  | ✓  | ✓   | ✓   | ✓   |     |     |     |     |     |     |     |   |
|        | 6"  | ✓  | ✓   | ✓   | ✓   | ✓   | ✓   | ✓   |     | ✓   |     | ✓   |   |
|        | 8"  |    | ✓   | ✓   | ✓   | ✓   | ✓   | ✓   |     | ✓   | ✓   |     |   |
|        | 10" |    |     | ✓   | ✓   | ✓   | ✓   | ✓   |     | ✓   | ✓   |     |   |
|        | 12" |    |     |     | ✓   | ✓   | ✓   | ✓   |     | ✓   | ✓   | ✓   |   |
|        | 14" |    |     |     |     | ✓   |     | ✓   |     | ✓   |     |     |   |
|        | 16" |    |     |     |     |     | ✓   |     |     |     | ✓   |     |   |
|        | 18" |    |     |     |     |     |     | ✓   |     |     | ✓   | ✓   | ✓ |
|        | 20" |    |     |     |     |     |     |     | ✓   |     |     |     |   |
|        | 22" |    |     |     |     |     |     |     |     |     |     |     |   |
|        | 24" |    |     |     |     |     |     |     |     |     | ✓   | ✓   | ✓ |
|        | 26" |    |     |     |     |     |     |     |     |     |     |     | ✓ |

- Steel construction with adjustable blades
- Opposed blade damper blades
- Double deflection—3/4" spacing
- White powder coat finish

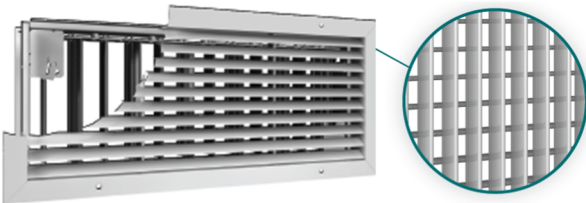

Adjustable double deflection supply grille

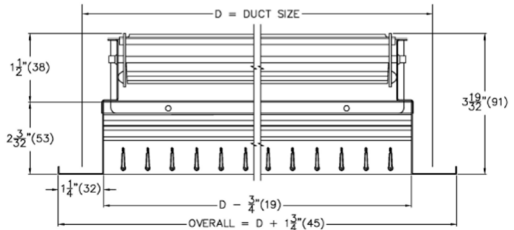

# Price

## Model 530—Fixed Blade Surface Mount Return Grille

Width

|        | 6"  | 8" | 10" | 12" | 14" | 16" | 18" | 20" | 22" | 24" | 30" | 36" | 46" | 48" |
|--------|-----|----|-----|-----|-----|-----|-----|-----|-----|-----|-----|-----|-----|-----|
| Height | 4"  | ✓  | ✓   | ✓   | ✓   |     |     |     |     |     |     |     |     |     |
|        | 6"  | ✓  | ✓   | ✓   | ✓   | ✓   | ✓   | ✓   | ✓   | ✓   |     |     |     |     |
|        | 8"  |    | ✓   | ✓   | ✓   | ✓   | ✓   | ✓   |     | ✓   |     |     |     |     |
|        | 10" |    |     | ✓   | ✓   | ✓   | ✓   | ✓   | ✓   | ✓   | ✓   |     |     |     |
|        | 12" |    |     |     | ✓   | ✓   | ✓   | ✓   |     | ✓   | ✓   | ✓   |     | ✓   |
|        | 14" |    |     |     |     | ✓   | ✓   | ✓   |     |     | ✓   | ✓   |     |     |
|        | 16" |    |     |     |     |     | ✓   | ✓   | ✓   |     | ✓   | ✓   |     |     |
|        | 18" |    |     |     |     |     |     | ✓   | ✓   |     | ✓   | ✓   | ✓   | ✓   |
|        | 20" |    |     |     |     |     |     |     | ✓   |     |     |     |     |     |
|        | 22" |    |     |     |     |     |     |     |     | ✓   |     |     |     | ✓   |
|        | 24" |    |     |     |     |     |     |     |     |     | ✓   | ✓   | ✓   | ✓   |
|        | 48" |    |     |     |     |     |     |     |     |     |     |     |     | ✓   |

- Steel construction with fixed blades
- 45 degree deflection - 3/4" spacing
- B12 White powder coat finish

| Lay In Sizes |            | Steel / Aluminum Available |
|--------------|------------|----------------------------|
| Neck Size    | Panel Size |                            |
| 22"x10"      | 24"x12"    | Steel / Aluminum           |
| 22"x22" *    | 24"x24"    | Steel / Aluminum           |
| 22"x46"      | 24"x48"    | Steel                      |

\* Sightproof Model RAME-T available

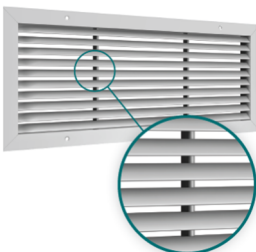

Fixed 45° deflection return grille

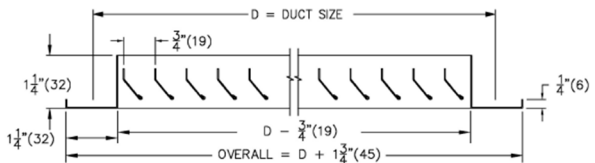

# Price

## Model STG1 Sight Proof Door Grilles with BF Frame

Available in sizes:

- 12"x6"
- 12"x12"
- 14"x14"
- 18"x12"
- 24"x18"
- 24"x24"
- 24"x12"



- Silver powder coat finish
- Steel construction
- Telescoping frame

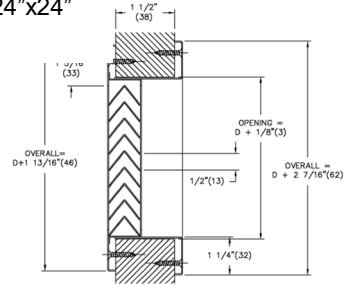

## Model 530FF-TB Louvered Face Filtered Return Grilles—Lay In

Available in size: 20"x20" inlet - 24"x24" Lay In Panel

- Steel Construction
- White Powder Coat Finish
- Fits 1" Filter
- Filter sold separately

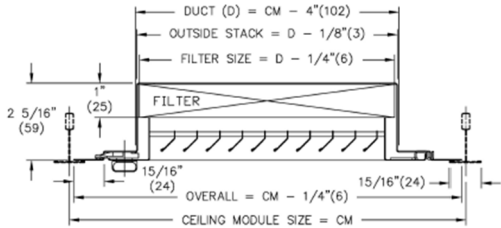
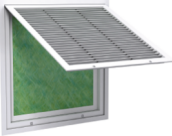

## Model 80FF-TB Egg Crate Filtered Return Grilles—Lay In

Available in size: 20"x20" inlet - 24"x24" Lay In Panel

- Aluminum Construction
- White Powder Coat Finish
- Fits 1" Filter
- Filter sold separately

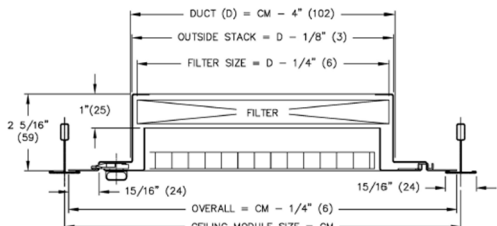
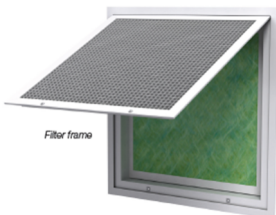

# Raymon-Donco

## Model ECRD Egg Crate Grilles with Integral Plenum

| Neck Size | Module Size |
|-----------|-------------|
| 6" Round  | 24"x12"     |
| 8" Round  | 24"x12"     |
| 10" Round | 24"x12"     |
| 6" Round  | 24"x24"     |
| 8" Round  | 24"x24"     |
| 10" Round | 24"x24"     |
| 12" Round | 24"x24"     |
| 14" Round | 24"x24"     |
| 16" Round | 24"x24"     |
| 18" Round | 24"x24"     |
| 20" Round | 24"x24"     |

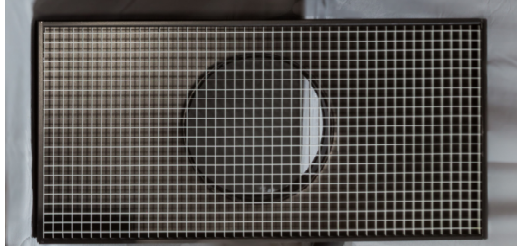

- Lay In Egg Crate Grille with Integral Plenum and 1/2"x1/2"x1/2" Aluminum Core
- 2-1/2" Tall Collar with Raised Bead
- White Powder Coat Finish on Core—Pre-Finished Black Interior on Plenum
- Surface Mount Frames and Dampers Available

## Egg Crate Grilles

| Lay In Sizes: |           |
|---------------|-----------|
| Panel Size    | Neck Size |
| 24"x12"       | 22"x10"   |
| 24"x24"       | 22"x22"   |
| 48"x24"       | 46"x22"   |

| Surface Mount Sizes: |  |
|----------------------|--|
| Neck Size            |  |
| 6"x6"                |  |
| 8"x8"                |  |
| 10"x10"              |  |
| 12"x12"              |  |
| 14"x14"              |  |
| 16"x16"              |  |
| 18"x18"              |  |
| 22"x22"              |  |
| 24"x12"              |  |
| 24"x24"              |  |

- Lay In (TB) or Surface Mount (SM) Egg Crate Grille with 1/2"x1/2"x1/2" Aluminum Core
- White Powder Coat Finish
- Surface Mount Frames Available



# Raymon-Donco

## Model STR Square to Round Transition

|         | 4" | 6" | 8" | 10" | 12" | 14" | 16" | 18" | 20" |
|---------|----|----|----|-----|-----|-----|-----|-----|-----|
| 6"x6"   | ✓  | ✓  |    |     |     |     |     |     |     |
| 8"x8"   |    | ✓  | ✓  |     |     |     |     |     |     |
| 9"x9"   |    | ✓  | ✓  |     |     |     |     |     |     |
| 10"x10" |    | ✓  | ✓  | ✓   |     |     |     |     |     |
| 12"x12" |    | ✓  | ✓  | ✓   | ✓   |     |     |     |     |
| 14"x14" |    |    |    |     | ✓   | ✓   |     |     |     |
| 15"x15" |    | ✓  | ✓  | ✓   | ✓   | ✓   |     |     |     |
| 16"x16" |    |    |    |     |     | ✓   | ✓   |     |     |
| 18"x18" |    |    |    |     |     | ✓   | ✓   | ✓   |     |
| 20"x20" |    |    |    |     | ✓   | ✓   | ✓   | ✓   |     |
| 22"x10" |    | ✓  | ✓  | ✓   |     |     |     |     |     |
| 22"x22" |    | ✓  | ✓  | ✓   | ✓   | ✓   | ✓   | ✓   | ✓   |



- 24GA galvanized construction
- 2-1/2" tall collar with raised bead
- Pre-finished black

## Model RTR Round to Round Transition

- 24GA galvanized construction
- 2-1/2" tall collar with raised bead
- Pre-finished black

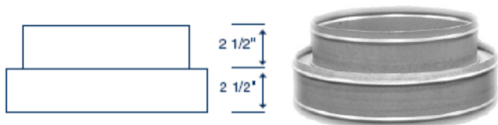

|     | 4" | 6" | 8" | 10" | 12" |
|-----|----|----|----|-----|-----|
| 6"  | ✓  |    |    |     |     |
| 8"  |    | ✓  |    |     |     |
| 10" |    |    | ✓  |     |     |
| 12" |    | ✓  | ✓  | ✓   |     |
| 14" |    |    |    | ✓   | ✓   |
| 15" |    |    |    |     | ✓   |

## Drywall Frames

| Size    | Rough In Opening |
|---------|------------------|
| 12"x12" | 12.375"x12.375"  |
| 24"x12" | 24.375"x12.375"  |
| 24"x24" | 24.375"x24.375"  |
| 24"x48" | 24.375"x48.375"  |

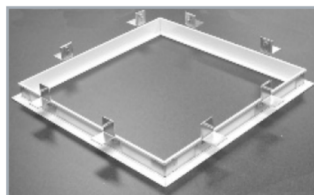

\* White Powder Coat Finish



# Price

## Model SDV5 Single Duct VAV Terminal Units

- 1/2" thick min 1.5 lb insulation
- 22GA zinc-coated steel housing
- Mechanically sealed and gasketed
- Leak resistant construction
- Slip and drive discharge
- Optional 3/4" fiber free liner available
- Access door with snap latches
- Pneumatic controls available
- Control enclosures available

| Inlet   | Outlet    | Length  | CFM Range |
|---------|-----------|---------|-----------|
| 6"      | 12"x8"    | 20-1/8" | 0-450     |
| 8"      | 12"x10"   | 20-1/8" | 0-800     |
| 10"     | 14"x12.5" | 20-1/8" | 0-1350    |
| 12"     | 16"x15"   | 20-1/8" | 0-2100    |
| 14"     | 20"x17.5" | 23-5/8" | 0-300     |
| 16"     | 24"x18"   | 23-5/8" | 0-4000    |
| 24"x16" | 38"x18"   | 19"     | 0-8000    |

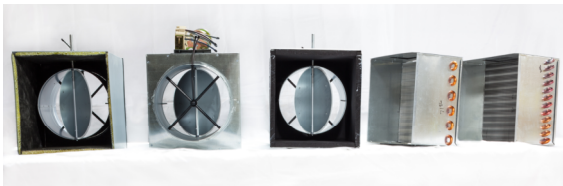
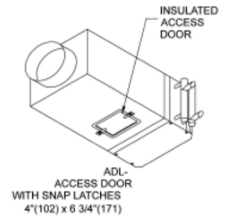
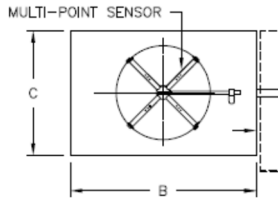

## Hot Water Coils for Model SDV5

| VAV Size | Coil Width | Coil Height | Coil Length | 1 Row | 2 Row |
|----------|------------|-------------|-------------|-------|-------|
| 6"       | 12"        | 8"          | 5"          | ✓     | ✓     |
| 8"       | 12"        | 10"         | 5"          | ✓     | ✓     |
| 10"      | 14"        | 12.5"       | 5"          | ✓     | ✓     |
| 12"      | 16"        | 15"         | 5"          | ✓     | ✓     |
| 14"      | 20"        | 17.5"       | 5"          | ✓     | ✓     |
| 16"      | 24"        | 18"         | 5"          | ✓     | ✓     |
| 24"x16"  | 38"        | 18"         | 5"          | ✓     | ✓     |

# Flexmaster

## Flexmaster Type 1 Flexible Duct

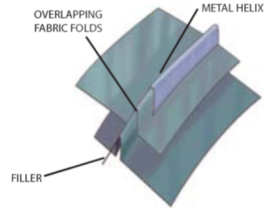

**LINER:** An acoustically transparent PE (Polyethylene) inner film allows mid-range sound energy to penetrate the duct wall. Mechanically Locked without adhesives.

**VAPOR BARRIER:** Black fire retardant Polyethylene material. Excellent strength at low temperatures. Will not age harden.

**HELIX:** Corrosive resistant galvanized steel, formed and mechanically locked to fabric.

**INSULATION:** Fiberglass insulation blanket, factory wrapped.

Available in 25' boxes of 6", 8", 10", 12", 14", and 16" with R6 thermal conductance  
 Flame spread = less than 25, Smoke developed = less than 50

## Flexmaster Type 6 Acoustical Flexible Duct

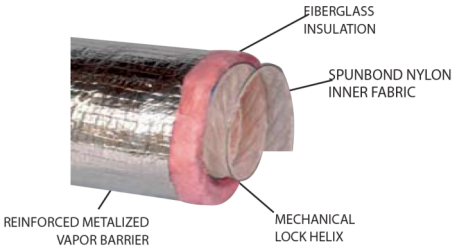

**LINER:** An acoustically transparent Spunbond Nylon fabric allows broadband sound energy to penetrate the duct wall. Mechanically Locked without adhesives.

**VAPOR BARRIER:** Fire retardant reinforced aluminum material. Excellent strength at low temperatures. Will not age harden.

Available in 25' boxes of 6", 8", 10", 12", 14", 16", 18", and 20" with R6 thermal conductance

The insertion loss (dB) of a 6 foot length of duct when tested in accordance with ASTM E 477 at a velocity of 1000 feet per minute shall be at least:

|              | 125 HZ | 250 HZ | 500 HZ | 1000 HZ | 2000 HZ | 4000 HZ |
|--------------|--------|--------|--------|---------|---------|---------|
| 8 inch dia.  | 5      | 10     | 22     | 34      | 22      | 17      |
| 12 inch dia. | 6      | 27     | 22     | 28      | 18      | 11      |

## Flexmaster FlexRight Elbow

Forms flexible duct into highly efficient 90 degree elbows. It is a Universal Mount, 1 piece fully adjustable radius forming brace to support 4" inch through 16" inch diameter flexible ducts. Nylon cable ties secure duct to duct support, (purchased separately and also available in stock)

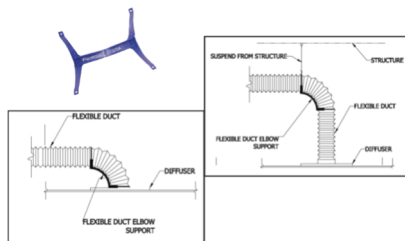

### Model FFCH Commercial Downflow Ceiling Heater

| Model Number                        | Volts/Phase   | Amps | Watts | BTU/HR | CFM |
|-------------------------------------|---|------|-------|--------|-----|
| FFCH548<br>(Heater Section<br>Only) | 208V / 1-3  | 19.2 | 4000  | 13700  | 300 |
|                                     | 208V / 1-3  | 14.2 | 3000  | 10200  | 300 |
|                                     | 208V / 1-3  | 9.6  | 2000  | 6800   | 300 |
| FFCH552<br>(Heater Section<br>Only) | 240V / 1-3  | 20.8 | 5000  | 17200  | 300 |
|                                     | 240V / 1-3  | 15.8 | 3800  | 13000  | 300 |
|                                     | 240V / 1-3  | 10.4 | 2500  | 8500   | 300 |
| FFCH557<br>(Heater Section<br>Only) | 277V / 1  | 18.1 | 5000  | 17200  | 300 |
|                                     | 277V / 1  | 13.7 | 3800  | 13000  | 300 |
|                                     | 277V / 1  | 9    | 2500  | 8500   | 300 |
| FFCH558<br>(Heater Section<br>Only) | 208V / 1-3  | 24.0 | 5000  | 17200  | 300 |
|                                     | 208V / 1-3  | 18.2 | 3800  | 13000  | 300 |
|                                     | 208V / 1-3  | 12   | 2500  | 8500   | 300 |
| FFCHRENW                            | Recess Mounting Enclosure Only - To Be Used With Above Heater Sections. Northern White Finish |      |       |        |     |

- Heater Section and Recess Mounting Enclosure required
- FFCHRENW “recessed enclosures” have no protrusions outside recess box, allowing the heater to recess only 7 in. into ceiling space. Mounts in T-Bar or permanent ceiling with trim ring
- Automatic Fan Delay
- Automatic Thermal Cutout
- Factory-wired for highest wattage, field-convertible to lower wattages. Factory-wired 1-PH, field convertible to 3-PH dual-phase units, maximum amp draw is listed. Amperage shown is for single phase.

#### Optional accessories:

- 25Amp Power Disconnect Switch (3 Pole)
- Unit Mounted Thermostat with 45-95 F Range
- Trim Kit for mounting on permanent ceilings



# Berko

## Model SRA Small Room Fan Forced Wall Heaters

| Model Number | Volts/Phase | Amps | Watts | BTU/HR |
|--------------|-------------|------|-------|--------|
| SRA1012DSF   | 120V/1      | 8.4  | 1000  | 3413   |
|              | 120V/1      | 4.2  | 500   | 1706   |
| SRA1512DSF   | 120V/1      | 12.5 | 1500  | 5120   |
|              | 120V/1      | 6.3  | 750   | 2560   |
| SRA2020DSF   | 208V/1      | 9.6  | 2000  | 6826   |
|              | 208V/1      | 4.8  | 1000  | 3413   |
| SRA2024DSF   | 208V/1      | 7.3  | 1500  | 5120   |
|              | 208V/1      | 3.6  | 750   | 2560   |
|              | 240V/1      | 8.4  | 2000  | 6826   |
|              | 240V/1      | 4.2  | 1000  | 3413   |



- Integral Thermostat with 40-85 F Range
- Built In Disconnect Switch
- Standard Recess Mount
- Surface Mount Frame Available

## Model SRA1000 Architectural Small Wall Heaters



- Integral Thermostat with 40-85 F Range
- Built In Disconnect Switch
- Standard Recess Mount
- Surface Mount Frame Available

| Model Number | Volts/Phase | Amps | Watts | BTU/HR |
|--------------|-------------|------|-------|--------|
| SRA1012DSAF  | 120V/1      | 8.4  | 1000  | 3413   |
|              | 120V/1      | 4.2  | 500   | 1706   |
| SRA1512DSAF  | 120V/1      | 12.5 | 1500  | 5120   |
|              | 120V/1      | 6.25 | 750   | 2560   |
| SRA2024DSAF  | 208V/1      | 7.3  | 1500  | 5120   |
|              | 208V/1      | 3.61 | 750   | 2560   |
|              | 240V/1      | 8.4  | 2000  | 6826   |
|              | 240V/1      | 4.2  | 1000  | 3413   |
| SRA2027DSAF  | 277V/1      | 7.3  | 2000  | 6826   |
|              | 277V/1      | 3.61 | 1000  | 3413   |
|              | 240V/1      | 6.25 | 1500  | 5120   |
|              | 240V/1      | 3.2  | 750   | 2560   |

# Berko

## Model FRC Commercial Fan Forced Wall Heaters

| Model Number | Volts/Phase | Amps | Watts | BTU/HR |
|--------------|-------------|------|-------|--------|
| FRC1512F     | 120V/1      | 12.5 | 1500  | 5118   |
| FRC4020F     | 208V/1      | 19.2 | 4000  | 13650  |
|              | 208V/1      | 9.6  | 2000  | 6825   |
| FRC4024F     | 240V/1      | 16.7 | 4000  | 13650  |
|              | 240V/1      | 8.3  | 2000  | 6825   |
|              | 208V/1      | 14.4 | 3000  | 10235  |
|              | 208V/1      | 7.2  | 1500  | 5120   |
| FRC4027F     | 277V/1      | 14.4 | 4000  | 13650  |
|              | 277V/1      | 7.22 | 2000  | 6825   |
|              | 240V/1      | 12.5 | 3000  | 10235  |
|              | 240V/1      | 6.3  | 1500  | 5120   |
| FRC4820F     | 208V/1      | 23.1 | 4800  | 16380  |



- Integral Thermostat with 40-90 F Range
- Disconnect, Fan Delay, Thermal Cutout
- Standard Recess Mount
- Surface Mount Frame Available
- Architectural Styling

## Model 2500 Electric Baseboard



- Available in 2', 3', 4', 5', 6', and 8' lengths
- Dual voltage, single phase
- Thermostats available also

| 120V | 240V / 208V |
|------|-------------|
| 2'   | -           |
| 3'   | 3'          |
| 4'   | 4'          |
| -    | 5'          |
| -    | 6'          |
| -    | 8'          |



# Berko

## Model HUHAA PRO Bundled Unit Heaters

Horizontal / Vertical Unit Heater

Bundles the HUHAA heater with the built in common accessories

This rugged unit heater works well in industrial settings. Its powerful output capacity makes it suitable for heating your loading dock or other indoor/ outdoor transition spaces.

**Includes:**

- Disconnect Switch
- 24VAC Transformer
- Single Stage Thermostat

**Optional Accessories:**

- Universal Wall and Ceiling Mounting Bracket



| Model Number  | Volts / Phase | kW  | Amps | Control Ckt. Volts |
|---------------|---------------|-----|------|--------------------|
| HUHAA320-PRO  | 208V / 1      | 3   | 14.5 | 24V                |
| HUHAA520-PRO  | 208V / 1-3    | 5   | 24   | 24V                |
| HUHAA720-PRO  | 208V / 1-3    | 7.5 | 36   | 24V                |
| HUHAA1020-PRO | 208V / 1-3    | 10  | 48   | 24V                |
| HUHAA548-PRO  | 480V / 3      | 5   | 6    | 24V                |
| HUHAA748-PRO  | 480V / 3      | 7.5 | 12   | 24V                |
| HUHAA1048-PRO | 480V / 3      | 10  | 12   | 24V                |

# Berko

## Model HUHAA Unit Heaters

Horizontal / Vertical Unit Heater (Heater Only)



### Optional Accessories:

- Single Pole and Two Stage Thermostats
- 25Amp or 60Amp Power Disconnect Switch (3 Pole)
- Universal Wall and Ceiling Mounting Bracket

| Model Number | Volts / Phase  | kW        | Amps      | Temp Rise | Control Ckt. Volts |
|--------------|----------------|-----------|-----------|-----------|--------------------|
| HUHAA527     | 277V / 1       | 5         | 18        | 45        | 277V               |
| HUHAA724     | 208/240V / 1-3 | 5.6 / 7.5 | 27 / 31.3 | 37        | 24V                |
| HUHAA1020    | 208V / 1-3     | 10        | 48        | 49        | 24V                |
| HUHAA1024    | 208/240V / 1-3 | 7.5 / 10  | 36 / 42   | 49        | 24V                |

# Aerotech

## Hot Water Radiant Ceiling Panels

- Available in 24"x24" and 24"x48" Lay In Panels



# GREE Kinghome

## Ultrnixx Heat Pump Condensing Unit

- Cost competitive with code compliant furnaces and air conditioning
- Reliable with fewer parts to fail
- Built to operate in Wisconsin's climate (rated to -22F)
- Simple to install, no complicated equipment required
- Useful for new construction and retrofits
- Very efficient (18-20 SEER)
- Terrific for multi-family applications
- Can be paired with any furnace or air handler



| Model                                       |         |         | KU36UHO             |                     | KU60UHO             |                     |
|---|---------|---------|---------------------|---------------------|---------------------|---------------------|
| Capacity Range                              |         | Ton     | 2                   | 3                   | 4                   | 5                   |
| Capacity                                    | Cooling | Btu/h   | 24,000              | 36,000              | 48,000              | 54,000              |
|   | Heating | Btu/h   | 24,000              | 36,000              | 48,000              | 54,000              |
| Power Supply                                |         | V,Ph,HZ | 208-230/1/60        | 208-230/1/60        | 208-230/1/60        | 208-230/1/60        |
| SEER  |         |         | 20                  | 18                  | 17                  | 17                  |
| EER   |         |         | 11.5                | 11                  | 10.5                | 10.5                |
| HSPF  |         |         | 10.5                | 10                  | 10                  | 10                  |
| MCA   |         | A       | 18                  | 24                  | 36                  | 40                  |
| MOP   |         | A       | 20                  | 35                  | 45                  | 50                  |
| Sound Pressure                              | Level   | dB(A)   | 60                  | 62                  | 64                  | 65                  |
| Connecting Pipe                             | Liquid  | Inch    | 3/8                 | 3/8                 | 3/8                 | 3/8                 |
|   | Gas     | Inch    | 3/4                 | 3/4                 | 3/4                 | 3/4                 |
| Dimension<br>(W×D×H)                        | Outline | Inch    | 37×18.125×32.25     | 37×18.125×32.25     | 39.375×14.625×53.75 | 39.375×14.625×53.75 |
|   | Package | Inch    | 42.625×22.625×38.25 | 42.625×22.625×38.25 | 45×18.875×59.375    | 45×18.875×59.375    |
| Net Weight / Gross Weight                   |         | lbs     | 217.2/240.3         | 217.2/240.3         | 304/328             | 304/328             |
| Temperature Operation Range For Cooling (F) |         |         | 5~125.6             | 5~125.6             | 5~125.6             | 5~125.6             |
| Temperature Operation Range For Heating (F) |         |         | <b>-22~75.2</b>     | <b>-22~75.2</b>     | <b>-22~75.2</b>     | <b>-22~75.2</b>     |



# GREE Kinghome

## Ultrnixx Air Handler

- Compatible with most standard 24V thermostats
- Little training needed for experienced installers
- Compact space saving design; perfect for installation with space limitation
- Reliable with fewer parts to fail
- Built to operate in Wisconsin's climate (rated to -22F)
- Useful for new construction and retrofits

### Ultrnixx Heating and Cooling

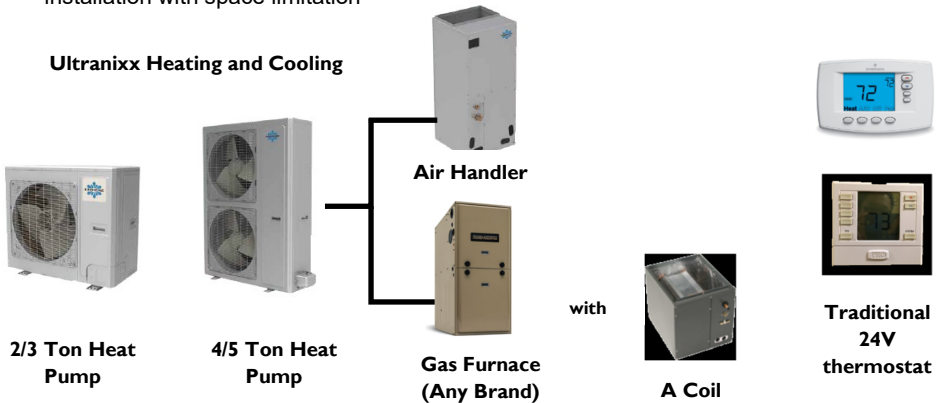

| Model                     |         |         | KU24UHI              | KU36UHI              | KU48UHI              | KU60UHI              |
|---------------------------|---------|---------|----------------------|----------------------|----------------------|----------------------|
| Capacity                  | Cooling | Btu/h   | 24,000               | 36,000               | 48,000               | 57,000               |
|                           | Heating | Btu/h   | 24,000               | 36,000               | 48,000               | 57,000               |
| Power Supply              |         | V,Ph,Hz | 208-230/1/60         | 208-230/1/60         | 208-230/1/60         | 208-230/1/60         |
| Power Consumption         |         | W       | 150                  | 200                  | 400                  | 500                  |
| Air Flow Volume           |         | CFM     | 950                  | 1000                 | 1600                 | 1750                 |
| MCA                       |         | A       | 5                    | 5                    | 8                    | 8                    |
| ESP (Max)                 |         | In wg   | 0.4                  | 0.4                  | 0.5                  | 0.5                  |
| Sound Pressure Level      |         | dB(A)   | 48                   | 49                   | 52                   | 53                   |
| Connecting Pipe           | Liquid  | Inch    | 3/8                  | 3/8                  | 3/8                  | 3/8                  |
|                           | Gas     | Inch    | 3/4                  | 3/4                  | 3/4                  | 3/4                  |
| Dimension                 | Outline | Inch    | 21-1/4x21-1/4x48-1/4 | 21-1/4x21-1/4x48-1/4 | 24-7/8x21-1/4x48-1/4 | 24-7/8x21-1/4x48-1/4 |
| (WxDxH)                   | Package | Inch    | 23-1/2x24-           | 26x23-3/4x50         | 27x24-1/2x51         | 27x24-1/2x51         |
| Net Weight / Gross Weight |         | lbs     | 156.5/169.8          | 156.5/169.8          | 178/192              | 178/192              |

- Air Handler models available for high static applications in stock as well.

# GREE Kinghome

## Mini Split Product Overview

| Wall Mounted Type |                    |       |       |       |       |      |
|-------------------|--------------------|-------|-------|-------|-------|------|
| Name              | Capacity (BTU/hr)  | 12000 | 18000 | 24000 | 36000 | SEER |
| Lilac             | DC Inverter, R410A | ✓     | ✓     | ✓     |       | 18   |
| Violet            | DC Inverter, R410A |       |       | ✓     | ✓     | 23   |
| Orchid            | DC Inverter, R410A | ✓     | ✓     |       |       | 30.5 |

WiFi module available on 16-23 SEER, standard on 38 SEER  
 Available 115v & 208/230 V Single Phase from the factory

Lilac



Violet



Orchid



Model YAN1F1F  
 Wireless Controller  
 Standard



Model XK76 Wired 7  
 Day Programmable  
 Thermostat Optional



ODU 23 SEER Model  
 12000—36000 BTU/hr  
 Data Shown in table

# GREE Kinghome

## Mini Split Product Overview

| Model  | Lilac                         | Orchid                          | Lilac                      | Orchid                           | Violet                           | Lilac                      | Violet                           |
|--|-------------------------------|---------------------------------|----------------------------|----------------------------------|----------------------------------|----------------------------|----------------------------------|
|  | KW12HQ3<br>B8D                | KW12HUC<br>A4D                  | KW18HQ3<br>B8D             | KW18HUC<br>A4D                   | KW24HQ2<br>B8D                   | KW24HQ3<br>B8D             | KW36HQ2<br>B4D                   |
| Cooling Capacity<br>BTU/hr                     | 12,000                        | 12,000                          | 18,000                     | 18,000                           | 22,000                           | 22,000                     | 33,600                           |
| Heating Capacity<br>BTU/hr                     | 13,000                        | 13,000                          | 19,800                     | 19,000                           | 23,000                           | 24,000                     | 34,600                           |
| SEER   | 18                            | 23                              | 18                         | 21                               | 20                               | 18                         | 18                               |
| Heating Operation<br>Range                     | -13 to 75F                    | -22 to 75F                      | -13 to 75F                 | -22 to 75F                       | -4 to 75F                        | -13 to 75F                 | -4 to 75F                        |
| Cooling Operation<br>Range                     | 0 to 115 F                    | 0 to 129 F                      | 0 to 115 F                 | 0 to 129 F                       | 0 to 115 F                       | 0 to 115 F                 | 0 to 115 F                       |
| Power Supply                                   | 208/230V<br>1ph<br>60HZ       | 208/230V<br>1ph<br>60HZ         | 208/230V<br>1ph<br>60HZ    | 208/230V<br>1ph<br>60HZ          | 208/230V<br>1ph<br>60HZ          | 208/230V<br>1ph<br>60HZ    | 208/230V<br>1ph<br>60HZ          |
| Gas Piping<br>Connection                       | 3/8"                          | 1/2"                            | 1/2"                       | 5/8"                             | 5/8"                             | 5/8"                       | 5/8"                             |
| Liquid Piping<br>Connection                    | 1/4"                          | 1/4"                            | 1/4"                       | 1/4"                             | 1/4"                             | 1/4"                       | 1/4"                             |
| Outdoor Unit<br>Outline<br>W x H x D           | 30.5" x<br>21.25"<br>x12.625" | 35.375" x<br>23.25"<br>x14.875" | 38" x<br>27.5"<br>x15.625" | 35.625" x<br>31.125" x<br>16.75" | 42.625" x<br>19.25" x<br>33.625" | 38" x<br>27.5"<br>x15.625" | 39.375" x<br>31.125" x<br>16.75" |
| Outdoor Unit Net<br>Weight/<br>Gross<br>Weight | 69.5 / 75                     | 97 / 103.6                      | 97 / 106.9                 | 141.1 /<br>152.1                 | 142.2 /<br>153.2                 | 103.635 /<br>113.558       | 160.965 /<br>171.99              |





For questions about available quantities in stock, please reach out to your sales team or contact [warehouse@airflowreps.com](mailto:warehouse@airflowreps.com)

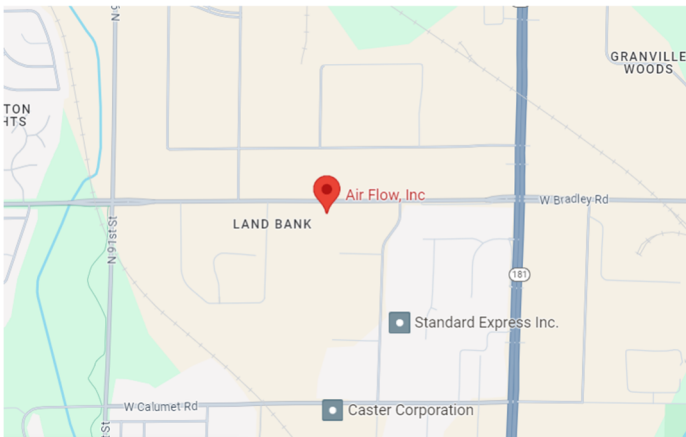

8355 West Bradley Road  
Milwaukee, WI 53223  
Phone: 414.351.1999  
Website: [www.airflowreps.com](http://www.airflowreps.com)